



BOTSWANA EXAMINATIONS COUNCIL
Botswana General Certificate of Secondary Education

CANDIDATE
NAME

CENTRE
NUMBER

--	--	--	--	--

CANDIDATE
NUMBER

--	--	--	--

SCIENCE : DOUBLE AWARD

0569/03

Paper 3

October/November 2014

2 hours

Candidates answer on the Question Paper.

No Additional Materials are required.

* 2 8 0 4 0 9 2 5 4 9 *

READ THESE INSTRUCTIONS FIRST

Write your Centre number, candidate number and name in the spaces provided at the top of this page.

Write in dark blue or black pen.

You may use a soft pencil for any diagrams, graphs or rough working.

Do **not** use staples, paper clips, highlighters, glue or correction fluid.

DO NOT WRITE IN ANY BARCODES.

Answer **all** questions.

Write your answers in the spaces provided on the Question Paper.

The number of marks is given in brackets [] at the end of each question or part question.

You may use a calculator.

A copy of the Periodic Table is printed on page 20.

For Examiner's Use

1	
2	
3	
4	
5	
6	
7	
8	
9	
10	
11	
12	
13	
14	
Total	

This document consists of 17 printed pages and 3 blank pages.



BLANK PAGE

1 Fig. 1.1 shows a pendulum clock.

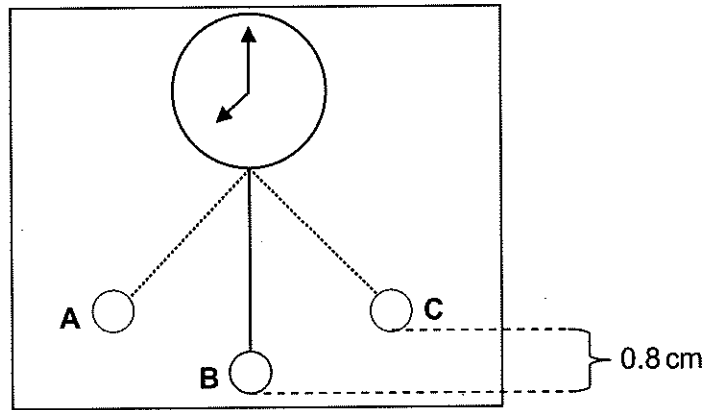

Fig. 1.1

A bob of mass 0.025 kg takes 1.0 second to complete one oscillation.

(a) Define an *oscillation*.

.....
[1]

(b) Determine the time taken by the bob to move from **A** to **B**.

time taken =[1]

(c) (i) Calculate the potential energy gained by the bob when it moves from **B** to **C**.
 ($g = 10 \text{ N/kg}$)

potential energy =[2]

(ii) Calculate the velocity of the bob when it passes point **B**.

velocity =[2]

(iii) What assumption did you make in answering (c) (ii)?

.....[1]



- 2 Street lamps are connected to a transformer which is supplied voltage from a power station. Fig. 2.1 shows the type of transformer the lamps are connected to.

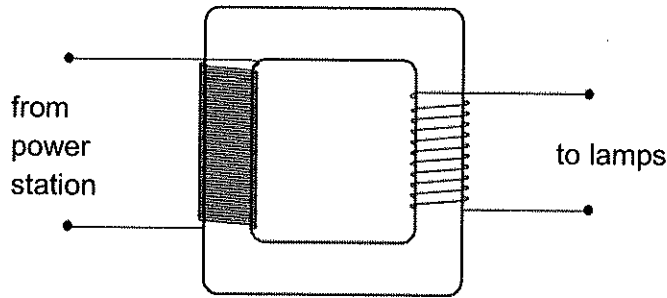

Fig. 2.1

- (a) Name the type of transformer shown in Fig. 2.1.

.....[1]

- (b) Explain how the voltage output to the street lamps is produced.

.....

[3]

- (c) Fig. 2.2 shows some identical street lamps connected in parallel.

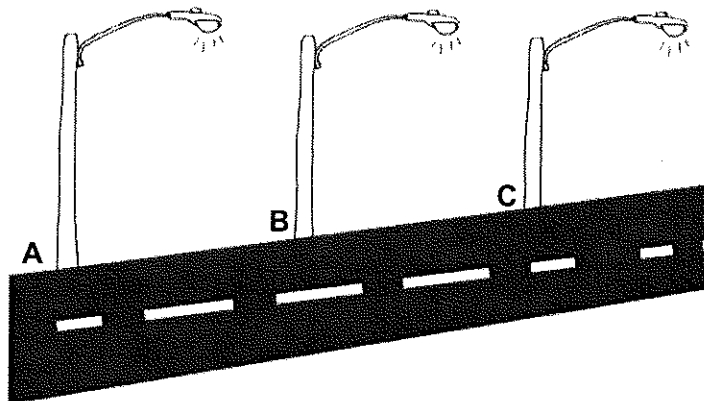

Fig. 2.2

The potential difference across lamp A is 240V. Each lamp is marked 40W; 240V.

- (i) State the value of the potential difference across lamp B.

potential difference.....[1]

(ii) Draw a simple circuit diagram to show how the lamps are connected.

[2]

(iii) Suggest **one** advantage of having the lamps in parallel.

[1]

(iv) Calculate the energy, in joules, converted by each lamp in 12 hours.

energy =[2]

(v) Calculate the resistance of each lamp. Use the equation power $(P) = \frac{V^2}{R}$.

resistance =[2]



- 3 Fig. 3.1 shows light travelling from air into a glass block of critical angle 42° . The diagram is not drawn to scale.

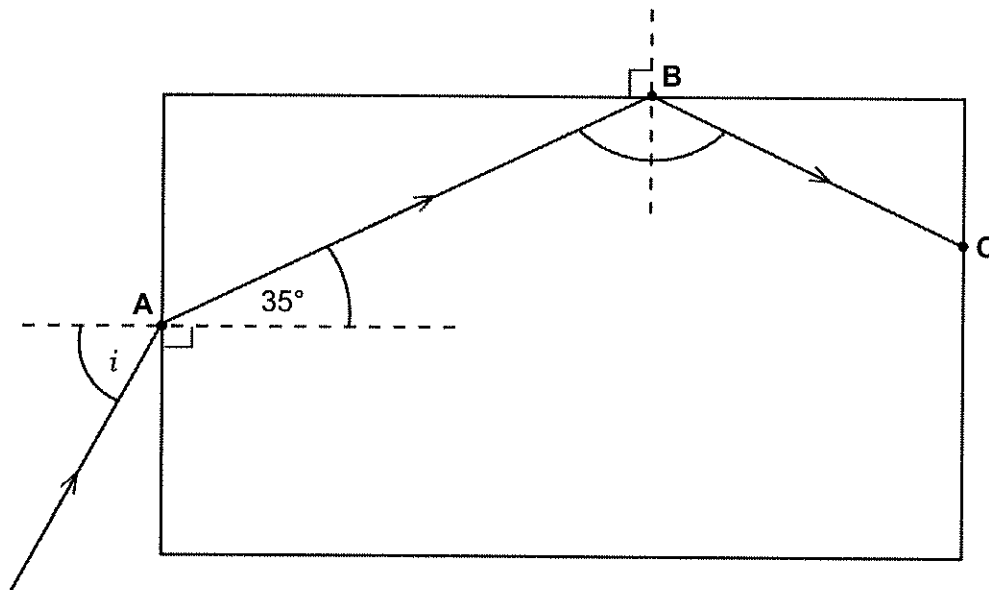

Fig. 3.1

- (a) Name the process occurring at point B.

.....[1]

- (b) In Fig. 3.1, complete the path of the light ray from point C.

[2]

- (c) The refractive index of glass is 1.5.
Calculate the angle of incidence i .

angle of incidence =[2]

- 4 Fig. 4.1 shows an experimental set-up used to study thermal energy transfer through different materials. Uniform aluminium and iron blocks were fixed to a copper rod.

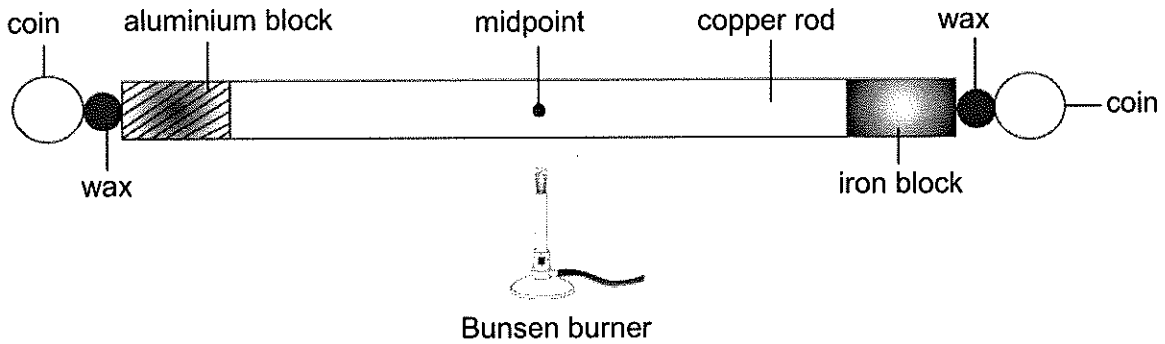

Fig. 4.1

Identical coins were attached to the ends of the blocks using wax. After heating the copper rod for a few minutes, the coin attached to the aluminium block fell down first.

- (a) Name the main method by which thermal energy from the flame reaches the aluminium block.

.....[1]

- (b) Describe the process by which thermal energy reaches the aluminium block.

.....

[2]

- (c) Explain why the copper rod is heated at the midpoint.

.....
[1]

- (d) What conclusion can be made from this experiment?

.....
[1]



- 5 Radioactive iodine is used to trace the flow of blood in the body of a patient. Radioactive iodine emits gamma radiation.

(a) What is the nature of gamma radiation?

.....[1]

(b) Suggest **two** reasons why an emitter of gamma radiation is suitable to be used as a tracer in the patient's body.

1

2[2]

(c) State **two** health hazards of radioactive emissions.

1

2[2]

- 6 Choose **one** substance from the list that fits the given descriptions. You may use each substance once, more than once, or not at all.

sodium carbonate	calcium oxide	sodium chloride
ammonia	nylon	chlorine

(a) It reacts with an acid to produce a gas that turns limewater milky.

.....[1]

(b) It is used in the manufacture of glass.

.....[1]

(c) It is a gas that bleaches damp red litmus paper.

.....[1]

(d) It is a macromolecular compound.

.....[1]

- 7 Sodium is an element in Group I of the Periodic Table.
It has the electron configuration of 2,8,1.

(a) State why sodium is in Group I.

.....[1]

(b) In which period is sodium found?

.....[1]

Explain your answer.

.....
.....[1]

(c) State how the sodium atom reacts with atoms of non-metals.

.....
.....[1]



- 8 Fig. 8.1 shows a blast furnace used in the extraction of iron.

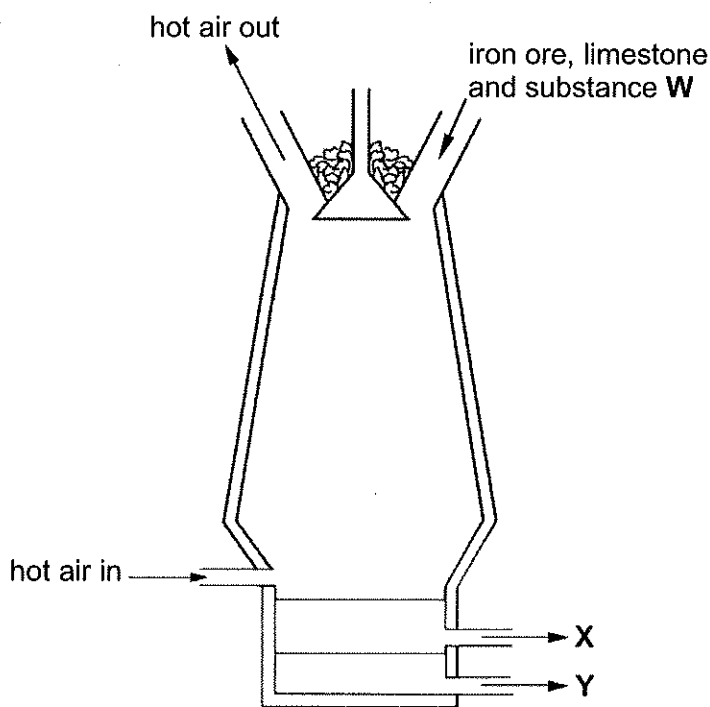

Fig. 8.1

- (a) (i) Name substance **W**.

.....[1]

- (ii) At which position, **X** or **Y**, is molten iron removed?

.....

Give a reason for your answer.

.....

.....[1]

- (b) A sample of the oxide of iron in the iron ore was analysed and found to contain 8.4 g of iron and 3.6 g of oxygen.
Show, by calculation, that the formula of the oxide contained in the ore is Fe_2O_3 .

[3]

- (c) The iron(III) oxide in the blast furnace is reduced to iron, Fe, as shown by the equation.



- (i) Balance the equation by writing numbers in the spaces provided. [1]

- (ii) Name the ore that contains iron(III) oxide, Fe_2O_3 .

.....[1]

- (d) Copper(I) oxide, Cu_2O , can also be reduced using carbon monoxide as shown by the equation.

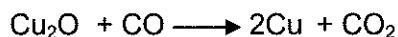

In an experiment, 28.8 g of copper(I) oxide was completely reduced to copper.

- (i) Calculate the relative molecular mass of copper(I) oxide, Cu_2O .

relative molecular mass =[2]

- (ii) Calculate the number of moles in 28.8 g of copper(I) oxide.

moles =[2]

- (iii) Calculate the number of moles of copper produced.

moles =[2]

- (iv) Calculate the mass of copper produced.

mass =[2]

- (v) Calculate the volume of carbon monoxide, CO, measured at room temperature and pressure (r.t.p.) needed to completely reduce 28.8 g of copper(I) oxide.
[1 mole of gas occupies 24 dm^3 at r.t.p.]

volume =[2]



- 9 Octane, C_8H_{18} , can be broken down to butane and butene as shown by the equation.

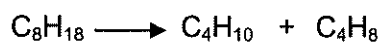

- (a) (i) Name the process represented by the equation.

.....[1]

- (ii) Name the catalyst used in this process.

.....[1]

- (b) Draw the structural formulae of two isomers of butane, C_4H_{10} .

[2]

- (c) Figures 9.1 and 9.2 show set-ups used to perform an experiment to distinguish between butane and butene gases.

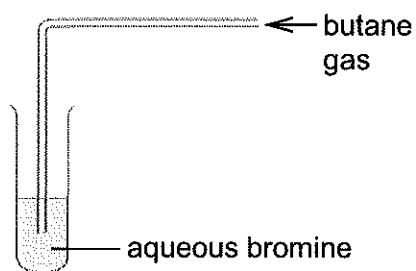

Fig. 9.1

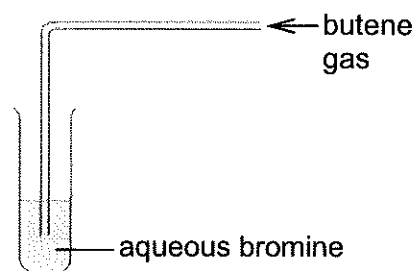

Fig. 9.2

- (i) State the observations made in Fig. 9.1 and Fig. 9.2.

observation in Fig. 9.1

.....[1]

observation in Fig. 9.2

.....[1]

- (ii) Explain the observations in (c)(i) in terms of the structural differences between the two gases.

.....

.....

.....[2]

10 Fig. 10.1 shows parts of the human digestive system and some blood vessels. The arrows show the direction of blood flow.

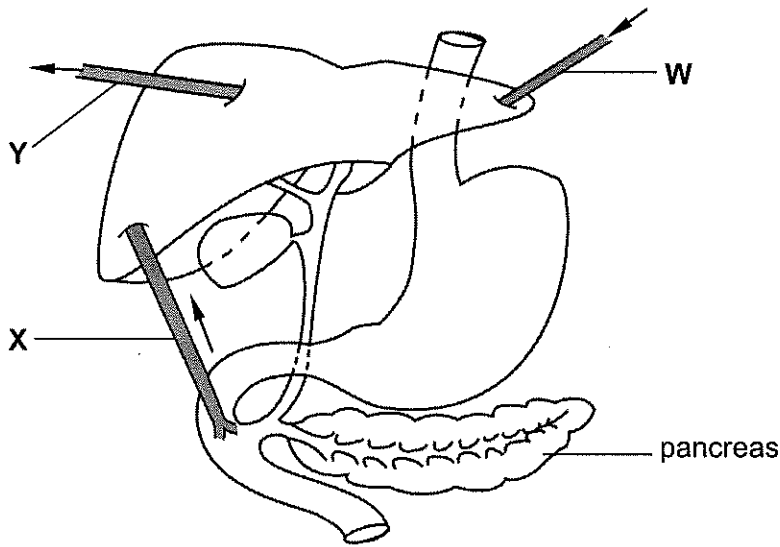

Fig. 10.1

(a) This person has recently eaten a meal containing protein.

Which blood vessel, W, X or Y, carries blood with the highest concentration of amino acids?

.....[1]

(b) (i) Name the enzyme that digests fats.

.....[1]

(ii) Describe how fats are digested in the duodenum.

.....

[3]

(c) The pancreatic duct can become blocked.

Explain why this would **not** affect blood sugar regulation.

.....
[1]



11 Fig. 11.1 shows a closed aquarium containing a green water plant. The aquarium is in a dark room.

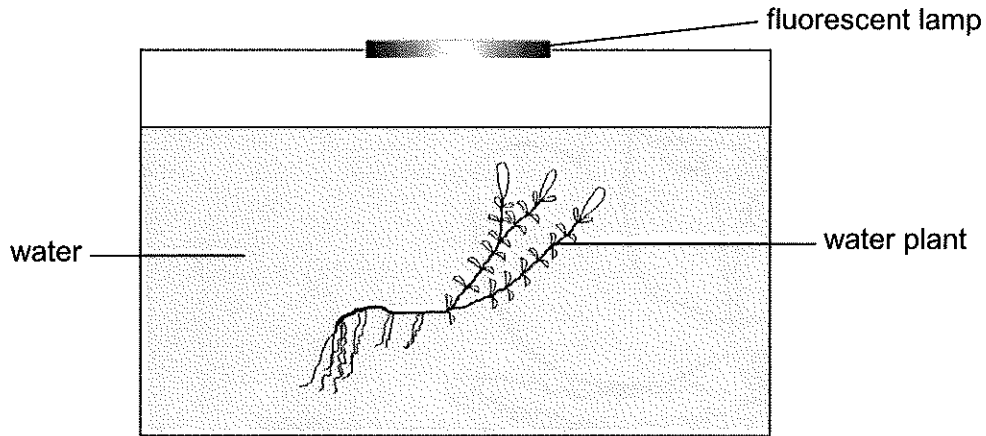

Fig. 11.1

(a) Name the mineral ion which must be present for the formation of the green pigment in plants.

.....[1]

(b) Explain why bubbles are produced by the plant when the lamp is switched on.

.....
.....
.....[2]

(c) Some fish were added to the aquarium.

Explain how the fish benefit from the presence of the plant when the lamp is switched on.

.....
.....
.....[2]

(d) After the fish were added, the plant produced more bubbles than before.

Suggest why.

.....
.....
.....[2]

12 Table 12.1 shows the amount of some substances in the blood that flows through the renal artery and renal vein.

Table 12.1

substance	amount in blood in renal artery/ arbitrary units	amount in blood in renal vein/ arbitrary units
oxygen	100.0	35.0
glucose	10.0	9.5
sodium salts	32.0	31.0
urea	3.0	0.5
water	180.0	178.0

(a) (i) Describe and explain the changes in the amount of glucose between the renal artery and renal vein.

.....

.....

.....

.....[3]

(ii) Suggest a reason for the difference in the amount of urea in the renal artery and renal vein.

.....

.....[1]

(b) A person with kidney failure receives regular dialysis treatment.

Explain how

(i) the loss of plasma proteins and red blood cells is prevented,

.....

.....

.....

.....[2]

(ii) the normal blood glucose concentration is maintained.

.....

.....[1]



13 Fig. 13.1 shows a longitudinal section of a bean seed.

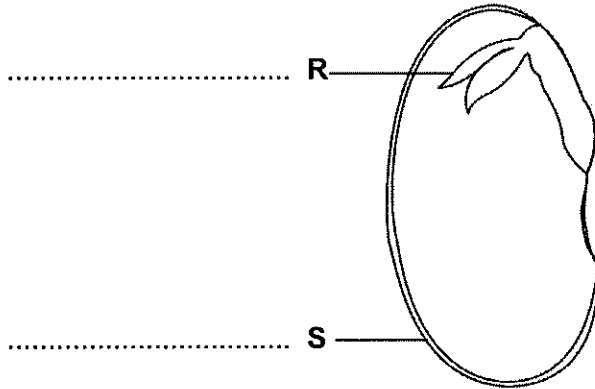

Fig. 13.1

(a) On Fig. 13.1, name parts **R** and **S**. [2]

(b) Name the part of the flower from which the seed was formed.
.....[1]

(c) During germination, starch stored in the cotyledons is broken down.
Describe how the breaking down of starch occurs.
.....
.....
.....[2]

(d) Water is one of the factors necessary for germination.
Give a reason why water is needed.
.....[1]

14 Fig. 14.1 shows an example of an aquatic ecosystem.

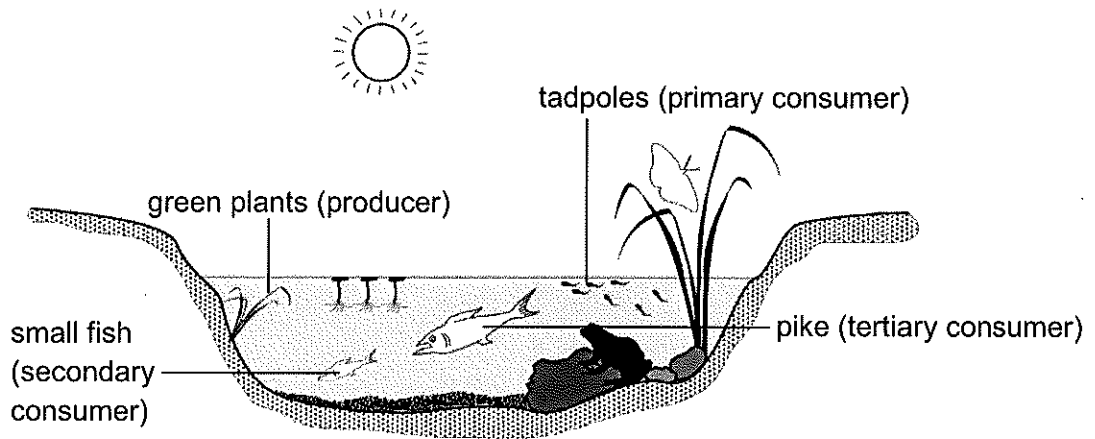

Fig. 14.1

(a) Using Fig. 14.1, construct a food chain with four trophic levels.

.....
[1]

(b) Name the principal source of energy for the food chain you have drawn.

.....[1]

(c) All the small fish were killed by a disease.

Describe and explain how this may affect the population of

(i) pike,

.....
[2]

(ii) green plants.

.....
[2]

(d) The pond is surrounded by farmland. Large numbers of green algae suddenly appear on the surface of the pond.

Suggest the most likely cause of this algal growth.

.....[1]



BLANK PAGE

BLANK PAGE

Permission to reproduce items where third party owned material protected by copyright is included has been sought and cleared where possible. Every reasonable effort has been made by the publisher (BEC) to trace copyright holders, but if any items requiring clearance have unwittingly been included, the publisher will be pleased to make amends at the earliest possible opportunity.



DATA SHEET
The Periodic Table of the Elements

		Group																																					
I	II	III	IV	V	VI	VII	0					0																											
7 Li Lithium 3	9 Be Beryllium 4	1 H Hydrogen 1	11 B Boron 5	12 C Carbon 6	14 N Nitrogen 7	18 O Oxygen 8	20 Ne Neon 10	27 Al Aluminium 13	28 Si Silicon 14	31 P Phosphorus 15	32 S Sulphur 16	35.5 Cl Chlorine 17	40 Ar Argon 18																										
39 K Potassium 19	40 Ca Calcium 20	45 Sc Scandium 21	48 Ti Titanium 22	51 V Vanadium 23	52 Cr Chromium 24	55 Mn Manganese 25	56 Fe Iron 26	59 Co Cobalt 27	59 Ni Nickel 28	64 Cu Copper 29	65 Zn Zinc 30	70 Ga Gallium 31	73 Ge Germanium 32	75 As Arsenic 33	79 Se Selenium 34	80 Br Bromine 35	84 Kr Krypton 36																						
85 Rb Rubidium 37	88 Sr Strontium 38	89 Y Yttrium 39	91 Zr Zirconium 40	93 Nb Niobium 41	96 Mo Molybdenum 42	101 Tc Technetium 43	101 Ru Ruthenium 44	106 Pd Palladium 46	106 Ag Silver 47	108 Cd Cadmium 48	112 In Indium 49	115 Sn Tin 50	119 Sb Antimony 51	122 Te Tellurium 52	127 I Iodine 53	131 Xe Xenon 54	133 Cs Cesium 55	137 Ba Barium 56	178 Hf Hafnium 72	181 Ta Tantalum 73	184 W Tungsten 74	186 Re Rhenium 75	190 Os Osmium 76	192 Ir Iridium 77	195 Pt Platinum 78	197 Au Gold 79	201 Hg Mercury 80	204 Tl Thallium 81	207 Pb Lead 82	209 Bi Bismuth 83	210 Po Polonium 84	210 At Astatine 85	222 Rn Radon 86						
226 Ra Radium 88	227 Ac Actinium 89											227 Fr Francium 87																											
													*58-71 Lanthanoid series										190-103 Actinoid series																
													140 Ce Cesium 58	141 Pr Praseodymium 59	144 Nd Neodymium 60	150 Sm Samarium 62	152 Eu Europium 63	157 Gd Gadolinium 64	159 Tb Terbium 65	162 Dy Dysprosium 66	165 Ho Holmium 67	167 Er Erbium 68	169 Tm Thulium 69	173 Yb Ytterbium 70	175 Lu Lutetium 71	232 Th Thorium 90	238 U Uranium 92	238 Pa Protactinium 91	238 Np Neptunium 93	238 Pu Plutonium 94	238 Am Americium 95	238 Cm Curium 96	238 Bk Berkelium 97	238 Cf Californium 98	238 Es Einsteinium 99	238 Fm Fermium 100	238 Md Mendelevium 101	238 No Nobelium 102	238 Lr Lawrencium 103

Key

a	X
b	

a = relative atomic mass
X = atomic symbol
b = proton (atomic) number

The volume of one mole of any gas is 24 dm³ at room temperature and pressure (r.t.p.).