



BOTSWANA EXAMINATIONS COUNCIL
Botswana General Certificate of Secondary Education

CANDIDATE
NAME

CENTRE
NUMBER

--	--	--	--	--

CANDIDATE
NUMBER

--	--	--	--



PHYSICS

Paper 3

0571/03

October/November 2016

1 hour 15 minutes

Candidates answer on the Question Paper.

Additional Materials: Electronic calculator
 300 mm ruler

READ THESE INSTRUCTIONS FIRST

Write your Centre number, candidate number and name in the spaces provided at the top of this page.

Answer **all** questions.

Write your answers in the spaces provided on the Question Paper.

You may lose marks if you do not show your working or if you do not use appropriate units.

Do not use staples, paper clips, highlighters, glue or correction fluid.

The number of marks is given in brackets [] at the end of each question or part question.

Take the weight of 1 kg to be 10N (i.e. acceleration of free fall = 10 m/s^2).

For Examiner's Use	
1	
2	
3	
4	
5	
6	
7	
8	
9	
10	
11	
TOTAL	

This document consists of **14** printed pages and **2** blank pages.



1 A car is moving at 90 km/h. A dog crosses the road 80 m ahead of the car and the driver immediately applies the brakes to allow the dog to cross.

(a) State the main energy change that occurs when the brakes are applied.

..... \longrightarrow [1]

(b) Fig. 1.1 shows the speed-time graph of the car when the driver saw the dog.

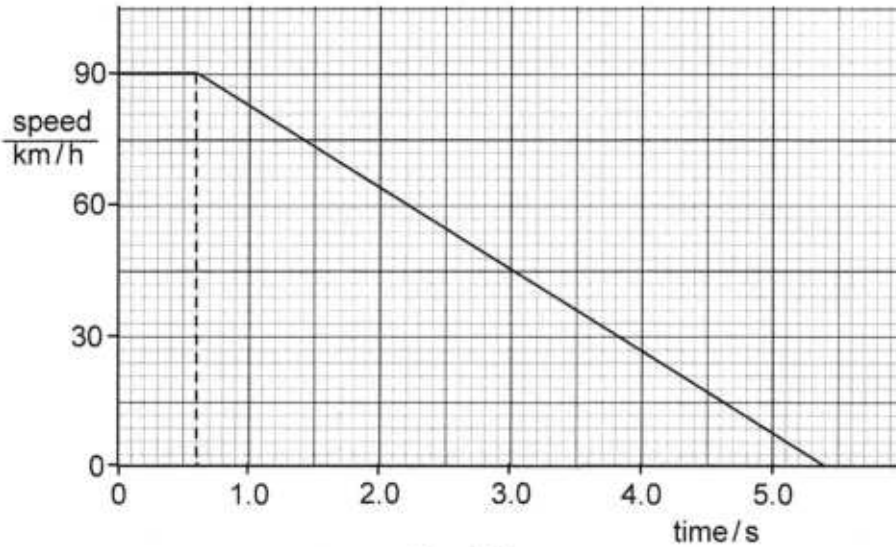

Fig. 1.1

Use the graph to determine

(i) the reaction time of the driver,

reaction time = [1]

(ii) the distance travelled by the car in 5.4 seconds.

distance = [3]

(c) Explain why a truck moving at the same speed as the car is likely to hit the dog.

.....
..... [2]

2 (a) Define the term *pressure*.

..... [1]

(b) An air bubble of volume 2.0 cm^3 forms 20 m below the surface of water in a lake. The bubble rises to the surface of the water. Atmospheric pressure is $1.0 \times 10^5 \text{ Pa}$, the density of water is 1000 kg/m^3 and $g = 10 \text{ m/s}^2$.

Calculate

(i) the total pressure exerted on the bubble 20 m below the surface of the water,

pressure = [3]

(ii) the volume of the bubble as it reaches the surface of the water.

volume = [2]

(c) State **one** assumption that you made when answering (b)(ii).

.....
..... [1]



3 (a) State **two** differences between boiling and evaporation.

- 1.
.....
- 2.
.....

[2]

(b) An athlete does some intensive training and starts to sweat.

Explain why the athlete feels cold after the training.

.....
.....
..... [2]

(c) When it is cold, people wear jackets to keep warm.

Explain how a jacket keeps the body warm.

.....
.....
..... [2]

- 4 Fig. 4.1 shows an energy source.

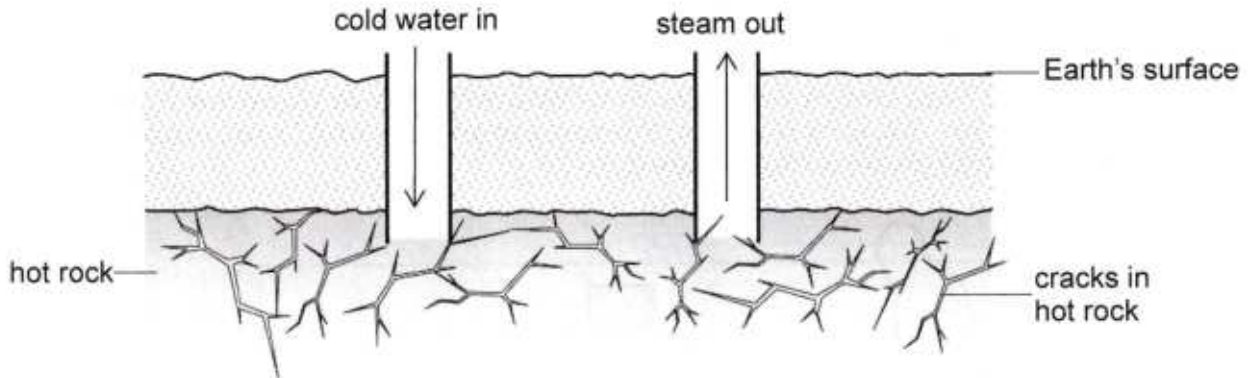

Fig. 4.1

1000 kg of cold water at $20\text{ }^{\circ}\text{C}$ is pumped down to the hot rock.
The water boils at $100\text{ }^{\circ}\text{C}$ and 100 kg of water turns into steam.

- (a) State the name of the energy source shown in Fig. 4.1.

..... [1]

- (b) Calculate

- (i) the energy needed to heat all the water from $20\text{ }^{\circ}\text{C}$ to $100\text{ }^{\circ}\text{C}$,
The specific heat capacity of water is $4200\text{ J}/(\text{kg }^{\circ}\text{C})$.

energy = [2]

- (ii) the energy needed to change 100 kg of water to steam.
The specific latent heat of vaporisation of water is $2.3 \times 10^6\text{ J}/\text{kg}$.

energy = [2]

- (c) Suggest **one** environmental impact of the source of energy in Fig. 4.1.

.....
..... [1]



5 (a) State the name of the electromagnetic waves used in mobile phone communication.

..... [1]

(b) Fig. 5.1 shows Kitso using a mobile phone to dial another mobile phone that is placed inside a glass jar. The jar is placed on a metal base and connected to a vacuum pump. A seal is used to prevent air from entering the jar.

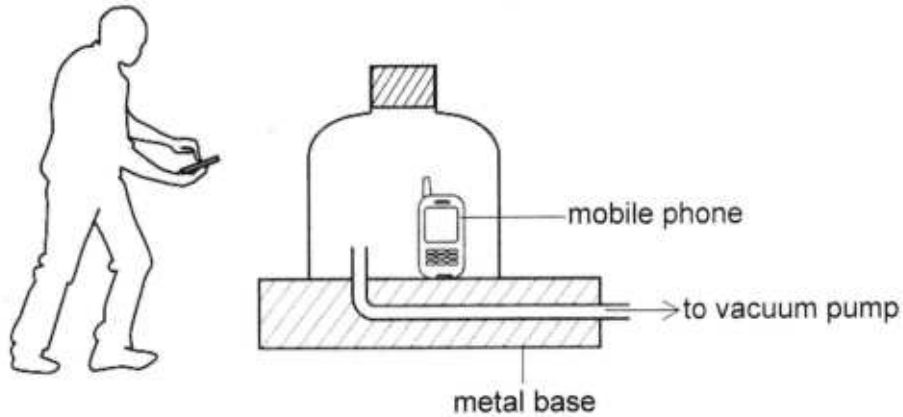

Fig. 5.1 (not to scale)

The phone in the jar is heard ringing and flashes of light are seen on its screen. The vacuum pump is switched on to remove the air from the jar when the phone is still ringing.

State and explain **two** observations that will be made about the light and sound from the phone.

1. observation
- explanation
2. observation
- explanation

[4]

(c) The electromagnetic waves used in mobile phone communication have a speed of 3.0×10^8 m/s in air. The wavelength of the waves is 0.17 m.

Calculate the frequency of the waves.

frequency = [2]

(d) Suggest a reason why the signal from the phone outside is able to reach the phone inside the jar when the air has been removed from the jar.

.....
..... [1]

- 6 Fig. 6.1 shows a ray of light emerging from a parallel-sided transparent glass block into air.

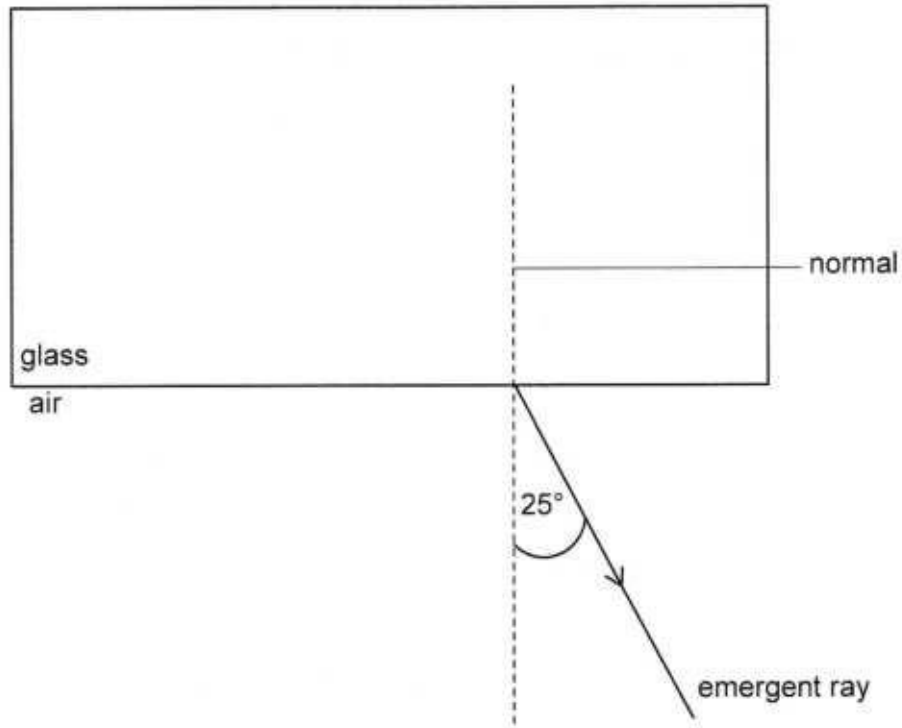

Fig. 6.1 (not to scale)

- (a) (i) On Fig. 6.1, complete the diagram by drawing the refracted ray inside the glass block and the incident ray in the air. [2]
- (ii) On Fig. 6.1, mark the angle of incidence i and the angle of refraction r as the ray of light enters the glass. [1]
- (b) The refractive index n of glass is 1.5.

Calculate the angle of refraction r of light entering the glass block.

$r = \dots\dots\dots$ [2]



- 7 Fig. 7.1 shows a piece of soft-iron used to protect an electronic component against a magnetic field produced by a bar magnet.

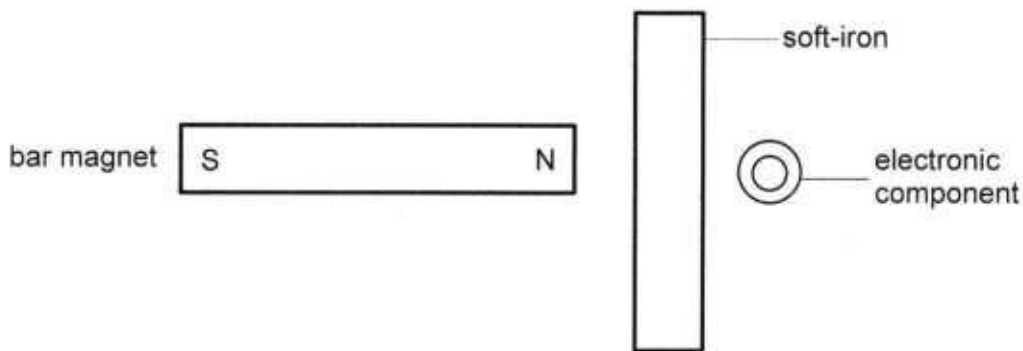

Fig. 7.1

- (a) (i) State the name of the method of protection used in Fig. 7.1.

..... [1]

- (ii) On Fig. 7.1, draw the magnetic field lines from the north pole until they reach the soft-iron. [2]

- (b) Fig. 7.2 shows a straight wire that is carrying current into a horizontal plane.

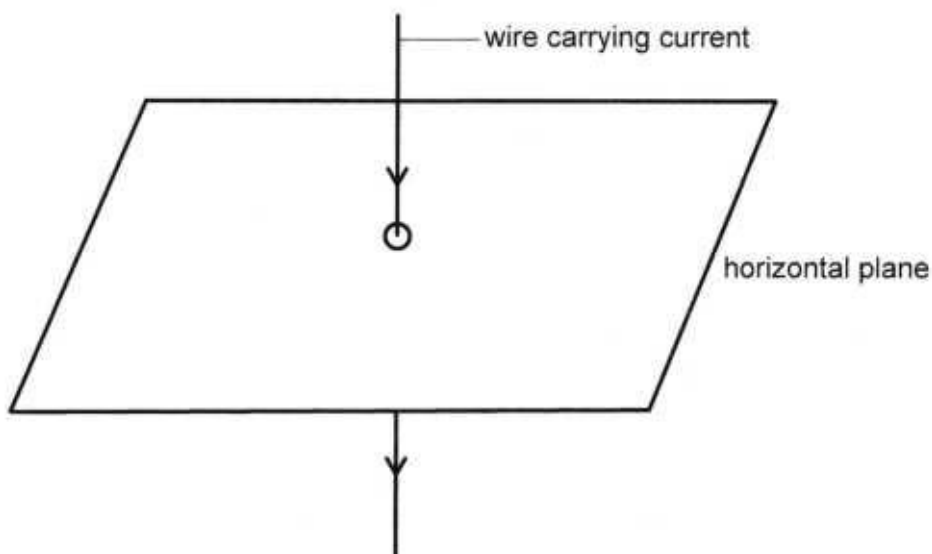

Fig. 7.2

- (i) On Fig. 7.2, draw the magnetic field pattern produced by the wire. [2]

- (ii) The wire carrying the current is placed between the two poles of a magnet as shown in Fig. 7.3.

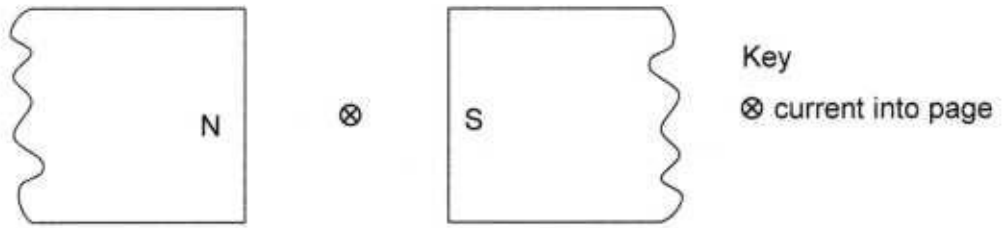

Fig. 7.3

On Fig. 7.3, draw an arrow to show the direction of the force acting on the wire. [1]



8 (a) Define the term *electric field*.

.....
..... [1]

(b) Fig. 8.1 shows two metal spheres A and B placed side by side and touching each other. The spheres are supported by insulating stands.

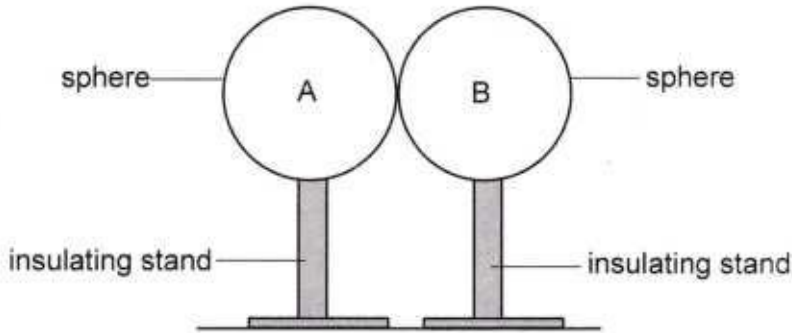

Fig. 8.1

A positively-charged rod is used to induce a positive charge on sphere A.

(i) On Fig. 8.1, show the position of the rod with a letter X. [1]

(ii) Explain how opposite charges are given to both spheres during induction.

.....
.....
..... [2]

(iii) Describe how the spheres can be left charged when the positively-charged rod is removed.

.....
..... [1]

(c) Fig. 8.2 shows a negatively-charged gold leaf electroscope.

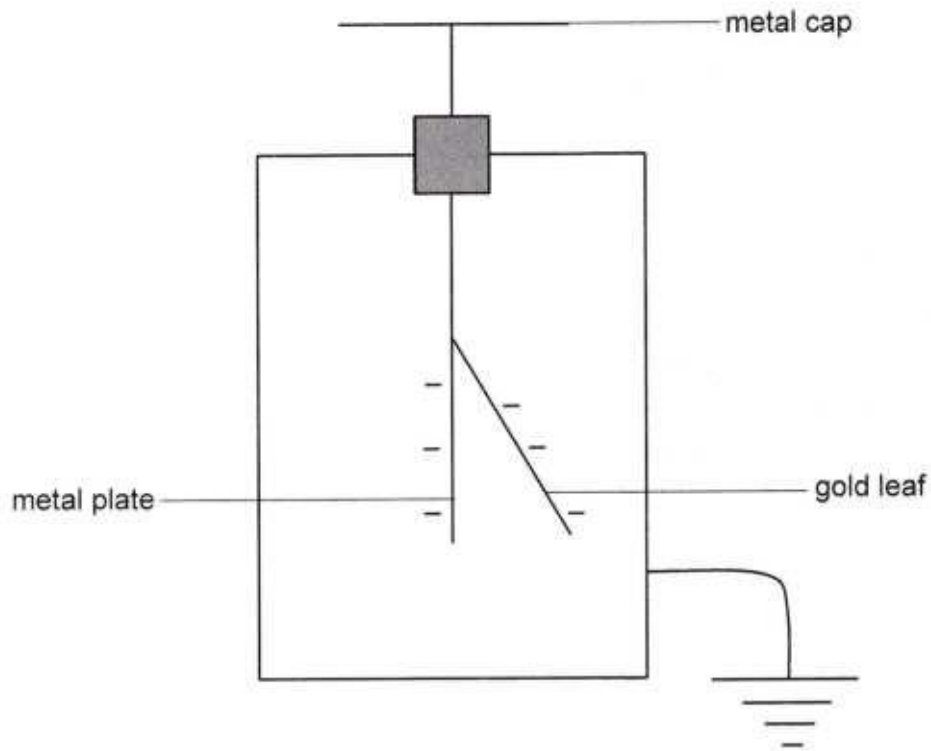

Fig. 8.2

When a charged rod is brought near the metal cap, the gold leaf rises further.

What is the charge on the rod? Explain your answer.

charge

explanation

[3]



- 9 Fig. 9.1 shows three resistors connected into a circuit.

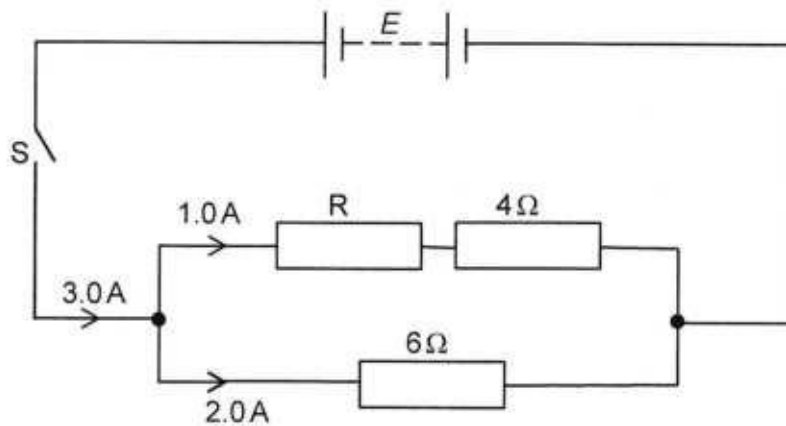

Fig. 9.1

The switch S is closed.

Calculate

- (a) the electromotive force (E) of the power supply,

$$E = \dots\dots\dots [2]$$

- (b) the total resistance of the circuit,

$$\text{total resistance} = \dots\dots\dots [1]$$

- (c) the resistance of resistor R.

$$\text{resistance} = \dots\dots\dots [2]$$

10 Fig. 10.1 shows a circuit which is used to switch on a lamp when it becomes dark.

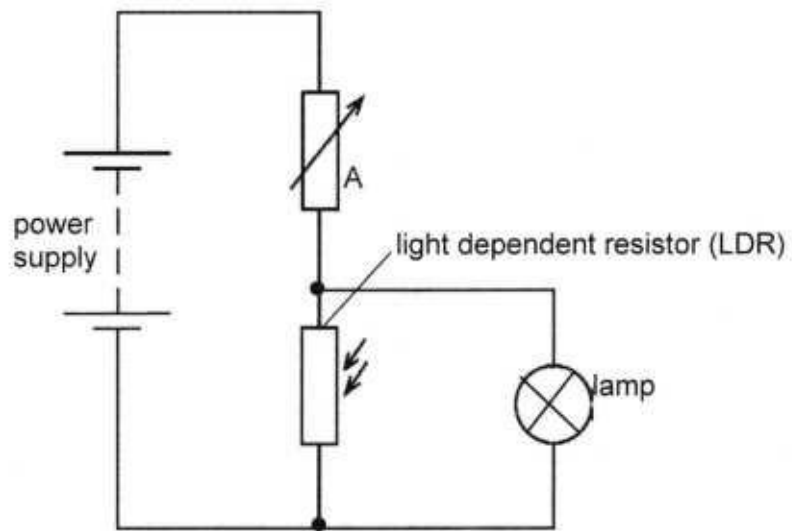

Fig. 10.1

(a) State the name of component A.

..... [1]

(b) Explain how the circuit switches on the lamp when it becomes dark.

.....

 [4]



11 (a) Define the term *isotopes*.

.....
 [1]

(b) Chlorine-37 and chlorine-35 are isotopes of chlorine. Chlorine-37 contains 17 protons.

What are the number of protons and the number of neutrons in chlorine-35?

number of protons =

number of neutrons =

[2]

(c) The Sun produces energy from a reaction represented by the equation



(i) Name this type of reaction.

..... [1]

(ii) State **one** difficulty of trying to use this reaction on Earth as a source of energy.

.....

..... [1]

(iii) The total mass of the products of the reaction, ${}^4_2\text{He}$ and ${}^1_0\text{n}$, is less than the total mass of the reactants by 3.3×10^{-29} kg.

The speed of light in a vacuum is 3.0×10^8 m/s.

Calculate the energy released from the reaction.

energy = [2]