



PHYSICS

0571/01

Paper 1 Multiple Choice

October/November 2015

1 hour

Additional Materials: Electronic calculator and/or Mathematical tables
 Soft clean eraser
 Soft pencil (type B or HB)
 Multiple Choice Answer Sheet



READ THESE INSTRUCTIONS FIRST

Do not open this booklet until you are told to do so.

Read the instructions on the separate Answer Sheet very carefully.

Write your name, Centre number and candidate number in the spaces provided on the Answer Sheet unless this has already been done for you.

Sign your name in the space provided on the Answer Sheet.

There are **forty** questions on this paper. Answer **all** questions. For each question, there are four possible answers **A, B, C** and **D**. Choose the **one** you consider correct and record your choice using a **soft pencil** on the separate Answer Sheet.

Each correct answer will score one mark. A mark will not be deducted for a wrong answer.

Any rough working should be done in this booklet.

Do not use staples, paper clips, highlighters, glue or correction fluid.



- 1 The diagram shows part of a micrometer screw gauge scale. The jaws of the micrometer are touching. The scale shows a zero error.

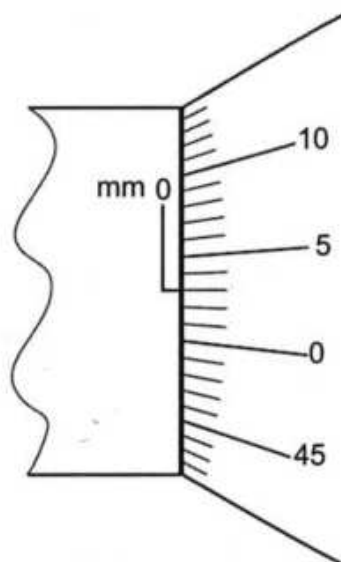

The micrometer screw gauge is used to measure the diameter of a thin piece of wire. The reading becomes 0.96 mm.

What is the diameter of the piece of wire?

- A 0.03 mm
 - B 0.93 mm
 - C 0.96 mm
 - D 0.99 mm
- 2 A car is accelerating while its speed remains constant.
- Which statement about the motion of the car must be correct?
- A It is moving along a curved road.
 - B It is moving along a straight road.
 - C It is moving down a slope.
 - D It is moving up a slope.

- 3 The diagram shows two identical beakers of mass 110 g placed on balances. The beakers contain water and liquid X of equal volumes. The density of water is 1.0 g/cm^3 .

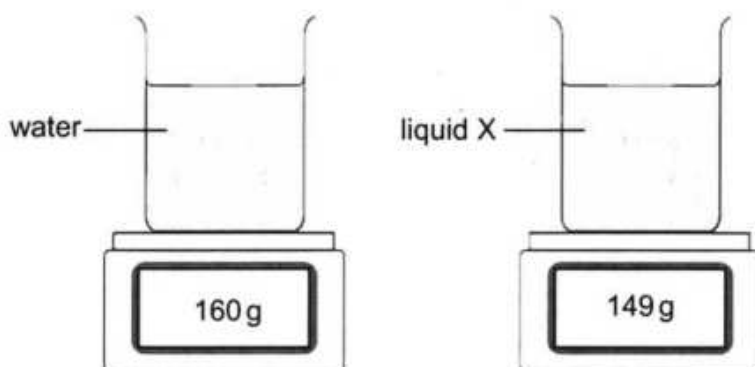

What is the density of liquid X?

- A 0.78 g/cm^3
 - B 0.93 g/cm^3
 - C 1.28 g/cm^3
 - D 2.98 g/cm^3
- 4 The diagram shows a boat moving on water.

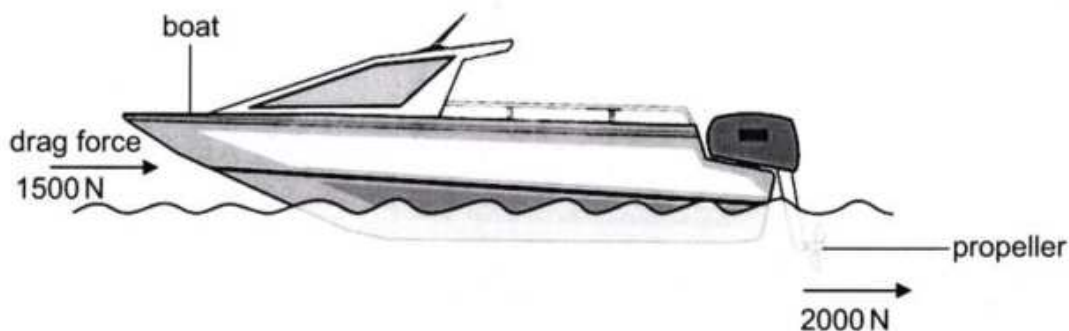

The propeller exerts a force of 2000 N on the water. The total drag force on the boat is 1500 N.

What is the resultant force acting on the boat?

- A 500 N
 - B 1500 N
 - C 2000 N
 - D 3500 N
- 5 Which factor affects the stability of an object?
- A base width
 - B density
 - C mass
 - D volume



- 6 A load of 10 N extends a spring by 4 cm. The spring obeys Hooke's law. The diagram shows two of the springs placed in parallel, carrying a load of 30 N.

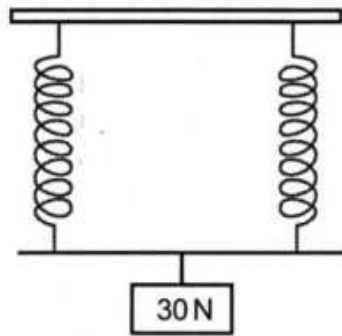

What is the extension produced on each spring?

- A 2 cm
 - B 6 cm
 - C 8 cm
 - D 12 cm
- 7 Which quantity is a product of force and the distance moved perpendicular to the force?
- A moment
 - B potential energy
 - C pressure
 - D work done
- 8 The diagram shows a glass container filled with water.

At which point does the water exert the greatest pressure?

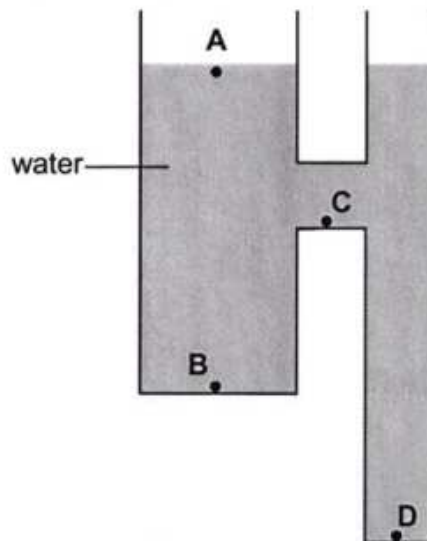

- 9 A substance is made up of particles that are close together and moving past each other randomly. The average speed of the particles is gradually increasing.

Which statement best describes the substance and the change which is taking place?

- A a liquid being heated
- B a liquid boiling
- C a solid being heated
- D a solid melting

- 10 A syringe contains a fixed mass of gas. The piston of the syringe is pushed to reduce the volume of the gas. The gas temperature remains constant.

What effect, if any, will the pushing of the piston have on the speed of gas particles and the pressure exerted by the particles on the walls of the syringe?

	speed of gas particles	pressure exerted
A	increases	increases
B	remains the same	remains the same
C	increases	remains the same
D	remains the same	increases

- 11 The diagram shows air bubbles moving from the bottom to the top of water behind a dam.

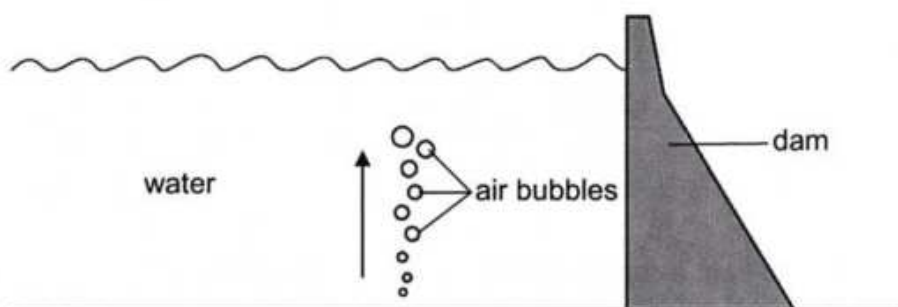

The bubbles get larger as they rise.

Why do the bubbles get larger?

- A The atmospheric pressure acting on the bubbles decreases.
- B The atmospheric pressure acting on the bubbles increases.
- C The water pressure acting on the bubbles decreases.
- D The water pressure acting on the bubbles increases.



- 12 When air is blown over hot tea in a saucer, the tea evaporates and its temperature changes.

How does the temperature of the tea change and why?

	temperature	reason
A	decreases	less energetic molecules leave the tea
B	decreases	more energetic molecules leave the tea
C	increases	less energetic molecules leave the tea
D	increases	more energetic molecules leave the tea

- 13 How is heat energy transferred in metals?

- A by movement of atoms only
- B by movement of electrons only
- C by vibration of atoms and movement of electrons
- D by vibration of atoms and movement of protons

- 14 A substance has a melting point of -114°C and a boiling point of 68°C .

In which states of matter does the substance exist at -10°C and 110°C ?

	-10°C	110°C
A	solid	liquid
B	solid	gas
C	liquid	solid
D	liquid	gas

- 15 A 100W heater is used to heat a copper block of mass 2 kg for 40s. The specific heat capacity of copper is $400\text{ J/kg}^{\circ}\text{C}$.

What is the maximum temperature rise of the block?

- A 0.125°C
- B 0.2°C
- C 5°C
- D 8°C

16 Which statement defines a *wavefront*?

- A A line joining points along the crest of a wave.
- B A line joining the trough and the crest of a wave.
- C The distance between successive crests of a wave.
- D The distance between the trough and the crest of a wave.

17 An object is placed in front of a thin converging lens of focal length 15 cm. The image formed by the lens has the same size as the object.

What is the distance of the object from the lens?

- A 15 cm
- B 20 cm
- C 30 cm
- D 40 cm

18 The diagram shows part of the electromagnetic spectrum.

P	X-rays	Q	visible light	R
---	--------	---	---------------	---

What are the components P, Q and R?

	P	Q	R
A	gamma rays	ultraviolet	infrared
B	radio waves	infrared	ultraviolet
C	gamma rays	infrared	ultraviolet
D	radio waves	ultraviolet	infrared



- 19 The diagram shows a ray of light passing through a semi-circular glass block.

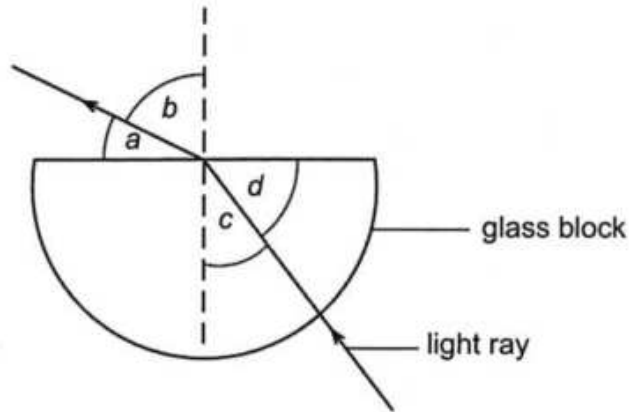

Which relationship gives the refractive index of the glass block?

- A $\frac{\sin a}{\sin d}$
- B $\frac{\sin b}{\sin c}$
- C $\frac{\sin c}{\sin b}$
- D $\frac{\sin d}{\sin a}$
- 20 A stone is dropped into the centre of a circular pond of diameter 12 m. The waves produced take 15 seconds to reach the sides of the pond.
- What is the speed of the waves?
- A 0.4 m/s
- B 0.8 m/s
- C 1.25 m/s
- D 2.5 m/s
- 21 Tshepho is standing in front of a high wall. She claps her hands and hears an echo 1.2 seconds later. The speed of sound in air is 320 m/s.
- How far is Tshepho from the wall?
- A 133 m
- B 192 m
- C 384 m
- D 533 m

22 The diagram shows an iron ring used in magnetic screening.

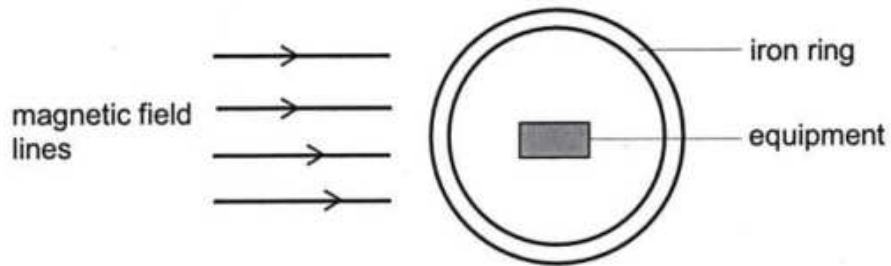

How does the iron ring screen the equipment from the magnetic field?

- A The iron ring absorbs the magnetic field.
- B The iron ring reflects the magnetic field.
- C The magnetic field is refracted by the iron ring.
- D The magnetic field is concentrated in the iron ring.

23 Which diagram correctly shows the electric field between two charged plates?

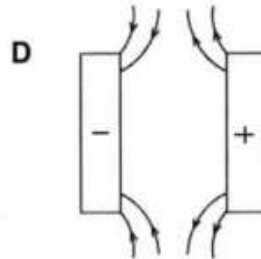
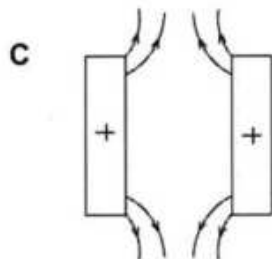
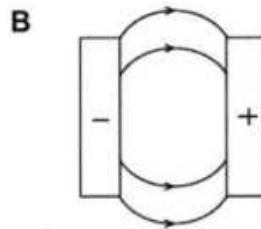
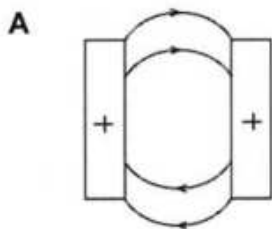

- 24 The diagram shows a positively charged object placed near the metal cap of a gold leaf electroscope.

The gold leaf is repelled from the metal rod.

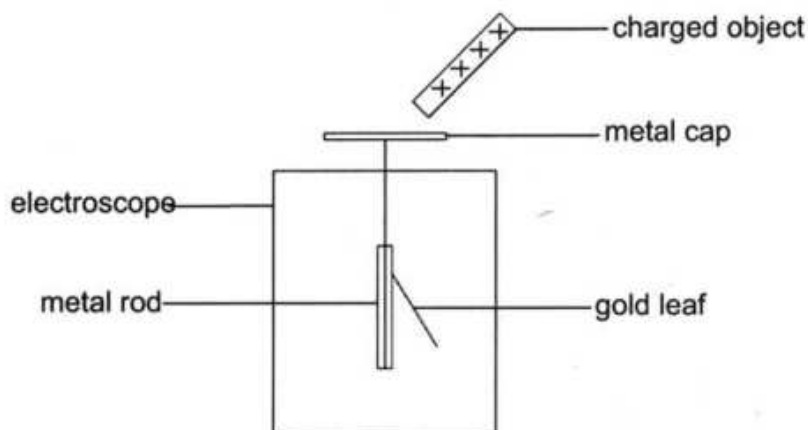

What causes the gold leaf to be repelled?

- A electrons move down to the gold leaf and metal rod
 - B electrons move up to the metal cap
 - C protons move down to the gold leaf and metal rod
 - D protons move up to the metal cap
- 25 The list shows steps carried out to charge an isolated metal sphere. The list is not in the correct order.

1. The sphere is earthed by touching it.
2. The earth connection is removed from the sphere.
3. A charged rod is brought near the sphere.
4. The charged rod is removed.

In which order should these steps be carried out to charge the sphere?

	first	→		last
A	1	2	4	3
B	1	3	4	2
C	3	1	2	4
D	3	4	1	2

26 The diagram shows an electric circuit.

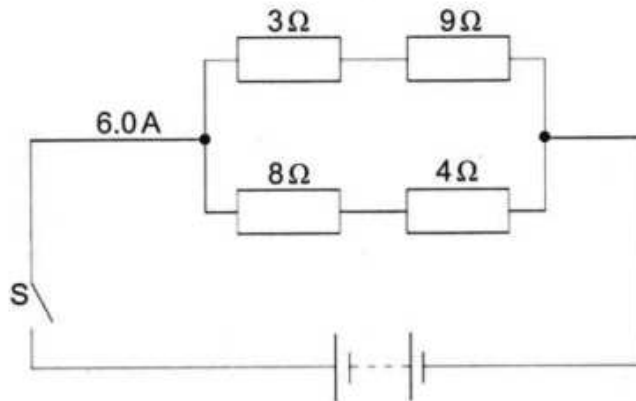

When the switch S is closed, there is a current of 6.0 A in the battery.

What is the current in the 3 Ω resistor?

- A 0.5 A
- B 2.0 A
- C 3.0 A
- D 6.0 A

27 The diagram shows the magnetic field produced by a current in a solenoid.

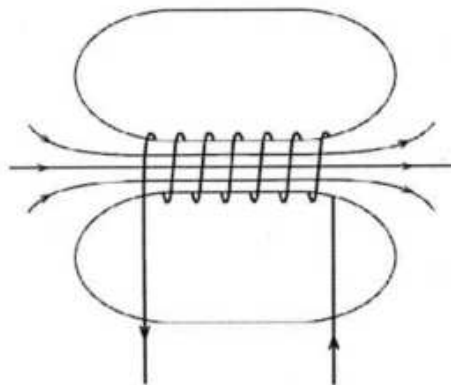

What effect will a larger current in the opposite direction have on the magnetic field strength and on the direction of the field?

	field strength	field direction
A	decreases	changes the direction
B	decreases	remains the same
C	increases	remains the same
D	increases	changes the direction



- 28 The diagram shows two resistors of different resistance connected in series with a cell.

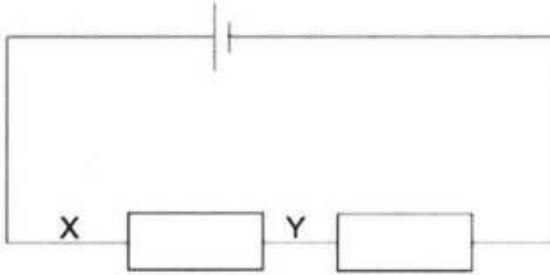

Which statement defines the potential difference across XY?

- A The power needed to drive a unit charge from the cell to point X.
 - B The power needed to drive a unit charge between X and Y.
 - C The work done in driving a unit charge from Y to the cell.
 - D The work done in driving a unit charge between X and Y.
- 29 A welding machine rated 1.2 kW is used for a period of time. The cost of using the machine is P2.40. The cost of electricity is 60 thebe per kWh.

How long was the machine used?

- A 0.03 hours
- B 2.0 hours
- C 3.3 hours
- D 4.8 hours

30 Which diagram shows the magnetic field pattern between two current carrying conductors?

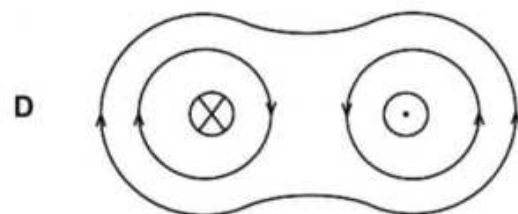
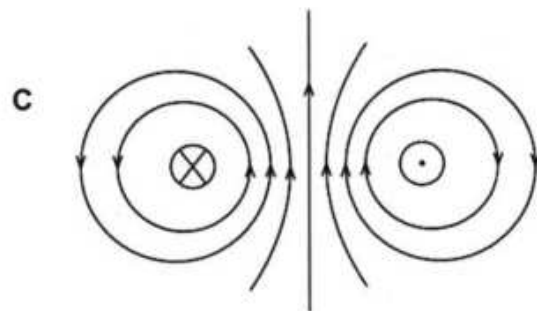
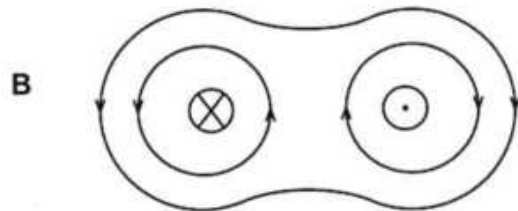
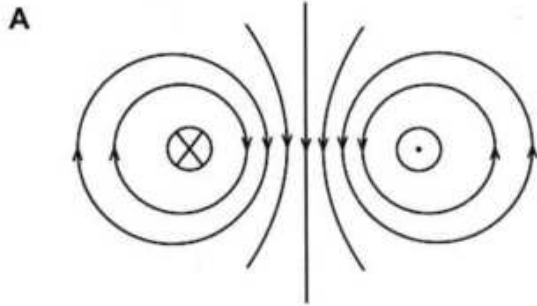

31 Which part of the direct current (d.c) motor reverses the direction of current through the coil every half-cycle?

- A armature
- B brushes
- C coil
- D commutator



- 32 The diagram shows a beam of electrons entering a magnetic field.

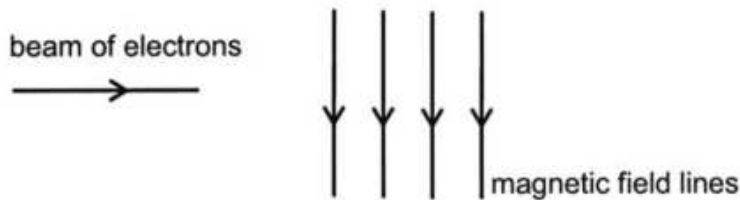

What will be the direction of the path of the beam of electrons when moving through the magnetic field?

- A into the plane of the page
- B out of the plane of the page
- C towards the bottom of the page
- D towards the top of the page

- 33 A transformer with 600 turns in the primary coil changes a voltage of 240V to 120V.

How many turns are there in the secondary coil of the transformer?

- A 48
- B 200
- C 300
- D 1200

- 34 An electric iron is marked 240 V, 1800W.

What is the rating of a fuse which can be used to best protect the iron?

- A 7 A
- B 8 A
- C 13 A
- D 15 A

- 35 The table shows part of the colour code for resistors.

black	brown	red	orange	yellow	green
0	1	2	3	4	5

Which colour combination gives a resistance of 1500Ω?

- A brown green brown
- B red green black
- C red green brown
- D brown green red

- 36 A signal generator is connected to the Y-input of a cathode ray oscilloscope (c.r.o). The time base is set to 0.2 seconds per division.

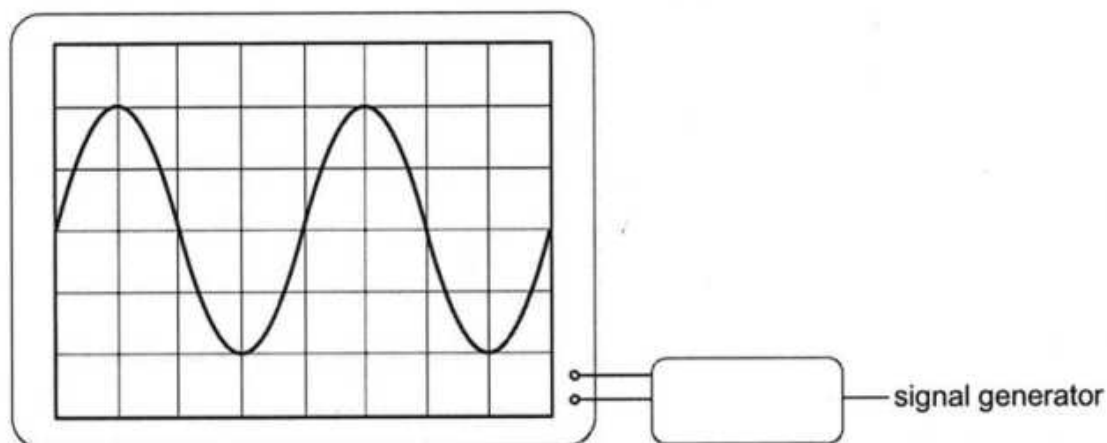

What is the period of the wave?

- A 0.1 s
 - B 0.2 s
 - C 0.4 s
 - D 0.8 s
- 37 Which statement is true about alpha, beta and gamma radiations?
- A They all ionise gases.
 - B They are all absorbed by a thin sheet of aluminium.
 - C They are all deflected by electric fields.
 - D They are all deflected by magnetic fields.
- 38 Which particle is used to split a uranium-235 nucleus in a nuclear reactor?
- A alpha
 - B beta
 - C neutron
 - D proton



39 A nuclide has a notation ${}_{23}^{48}\text{X}$.

Which row shows the atomic number and the mass number of an isotope of this nuclide?

	atomic number	mass number
A	23	50
B	24	48
C	48	24
D	50	23

40 The half-life of a radioisotope is 2400 years. The activity of the sample of the radioisotope is 720 counts/seconds.

How long does it take for the activity to fall to 90 counts / second?

- A 150 years
- B 300 years
- C 7200 years
- D 9600 years