



MATHEMATICS

0563/03

Paper 3

October/November 2015

2 hours 30 minutes

Additional Materials: Answer paper
Electronic calculator
Geometrical instruments

Graph Paper (2 sheets)
Mathematical tables (optional)



READ THESE INSTRUCTIONS FIRST

Write your answers on the separate answer paper provided.

Start each question on a fresh side of the page.

Write your centre number, candidate number and name on each sheet of answer paper you use.

Answer **all** questions.

All working must be clearly shown. The working should be done on the same sheet as the rest of the answer. Marks will be given for working which shows that you know how to solve the problem even if you get the answer wrong.

At the end of the examination, fasten all your work securely together using the string provided.

Do not use staples, paper clips, highlighters, glue or correction fluid.

The number of marks is given in brackets [] at the end of each question or part question.

The total of the marks for this paper is 125.

Electronic calculators may be used.

If the degree of accuracy is not specified in the question and if the answer is not exact, the answer should be given to three significant figures. Answers in degrees should be given to one decimal place.

In any question where the value of π is required, use the value from your calculator or take π as 3.142.

- 1 Maipelo tiles a square floor of area 144 m^2 . She uses square tiles of side length 30 cm.
- (a) Show that the number of tiles that are needed to cover the whole floor is 1600 . [2]
- (b) The tiles are packed and sold in boxes of 14 .
Calculate the number
- (i) of boxes Maipelo needs for the entire floor, [2]
- (ii) of tiles that will be left unused after tiling. [2]
- (c) A box of tiles costs P125.95 .
Calculate the total cost of tiles needed to cover the entire floor. [2]
- (d) The cost of transporting the tiles is 8% of the total cost of the boxes.
Calculate the cost of transporting the tiles. [2]
-

- 2 A sequence of numbers is $-3, 0.5, 10, 25.5, 47, \dots$
- (a) What is the next term of the sequence? [2]
- (b) Write an expression for the n th term of the sequence. [3]
- (c) Calculate the value of n for which the n th term is 302 . [3]
-

- 3 The formula for calculating the horsepower, H , of an engine is given by

$$H = \frac{d^2 N}{16},$$

where d is the cylinder bore, in centimetres, and N is the number of cylinders.

- (a) Express d in terms of H and N . [3]
- (b) The horsepower, H , of an 8 cylinder engine is 47.05 .
Calculate the cylinder bore, in centimetres. [2]
-
- 4 A runner takes 11 seconds to complete a 100 m race. The time is expressed correct to the nearest second and the distance is measured correct to the nearest 10 cm.
- (a) Write down the least possible distance. [1]
- (b) Calculate the minimum possible speed, in m/s, of the runner. [3]
-

5 A bag contains P2 coins and P1 coins only. The number of P2 coins is x and the number of P1 coins is y .

- (a) Write down an expression, in terms of x and/or y , for the total value of the
- (i) P2 coins, [1]
- (ii) P1 coins. [1]
- (b) The total amount of money in the bag is P100 .
Form an equation, in terms of x and y , for the total amount of money in the bag. [1]
- (c) The total number of coins in the bag is 60 .
Form an equation, in terms of x and y , to show this information. [2]
- (d) Solve simultaneously, the equations in (b) and (c) to determine the number of P2 coins and the number of P1 coins. [3]
- (e) Hence, or otherwise, calculate the total value of the P2 coins. [1]
-

6 A farmer has a ploughing field in the form of a quadrilateral $ABCD$ such that $AB = 480$ m, $BC = 430$ m and $AD = 450$ m. The size of $\hat{ABC} = 60^\circ$ and the size of $\hat{BAD} = 110^\circ$.

- (a) Using a scale of 1 cm to represent 50 m, construct a scale diagram of the ploughing field. [3]
- (b) Measure and write down the actual length of CD . [2]
- (c) The farmer is to locate a borehole inside the ploughing field.
- (i) The position of the borehole is such that it is equidistant from A and B . Construct the locus of points showing the possible positions of the borehole. [1]
- (ii) The borehole is also such that it is equidistant from AB and AD . Construct the locus of points showing the possible positions of the borehole. [1]
- (iii) Mark and label the position of the borehole, P . [1]
-

- 7 The table below shows a group of 25 students studying different syllabuses.

Syllabus	Number of students
Additional Mathematics	5
Music	5
Physical Education	7
Religious Education	8

- (a) One student is chosen at random from the group to attend a conference.
What is the probability that the student chosen studies Music? [1]
- (b) The student who is representing the group at the conference studies Additional Mathematics. From the remaining students, two more are chosen at random to participate in a tournament.
Calculate the probability that
- (i) they both study Additional Mathematics, [2]
- (ii) one student studies Religious Education and the other studies Physical Education. [3]

- 8 The diagram below shows the points O, A, B and C in a plane such that OC and AB are parallel. The ratio $OC : AB = 3 : 4$, $\vec{OA} = \mathbf{k}$ and $\vec{OC} = \mathbf{m}$.

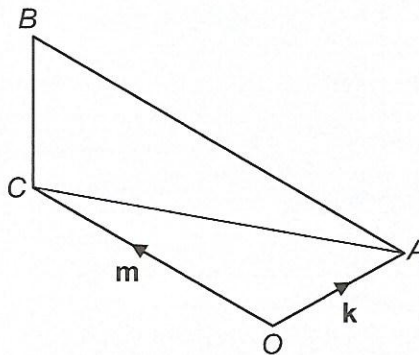

Express, in terms of \mathbf{k} and/or \mathbf{m} ,

- (a) \vec{AC} , [2]
- (b) \vec{AB} , [2]
- (c) \vec{CB} . [3]

- 9 The diagram below shows three points A , B and C . The bearing of C from A is 046° and the bearing of C from B is 310° . $AC = 500$ m and $BC = 420$ m.

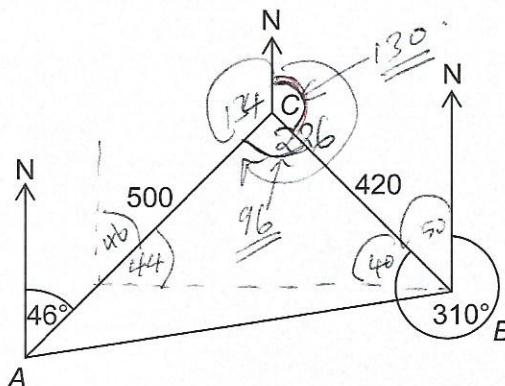

- (a) Calculate the bearing of A from C . [2]
- (b) Show that the size of $\hat{ACB} = 96^\circ$. [2]
- (c) Calculate the distance AB . [4]

- 10 The table below shows the times, t minutes, taken by 90 cyclists to complete a race.

Time, t (minutes)	$45 \leq t < 50$	$50 \leq t < 55$	$55 \leq t < 60$	$60 \leq t < 65$	$65 \leq t < 70$
Number of cyclists	5	14	22	25	24

- (a) Write down the midpoint of $45 \leq t < 50$. [1]
- (b) Calculate an estimate of
- (i) the mean, [3]
- (ii) the variance, [3]
- (iii) the standard deviation of the time taken, in minutes, to complete the race. [1]
- (c) **Without** drawing a cumulative frequency curve, calculate an estimate of the median time taken by the cyclists. [3]
- (d) At most 15% of the cyclists who recorded the best times for the race qualify for awards.
- Calculate the time taken by the last qualifying cyclist. [3]

- 11 A cylindrical iron rod of radius 2.5 cm has a height of 6 cm.
- (a) Calculate the volume of the iron rod. [2]
- (b) Iron has a density of 7.87 g/cm^3 .
Calculate, in grams, the mass of the iron rod. [2]
- (c) The rod is dipped into water up to 4 cm of its height.
Calculate the total surface area of the rod that will be covered by water. [3]

- 12 In the diagram below, the points A , B , C and D lie on the circumference of a circle of centre O . The line EF touches the circle at C . The size of $\hat{CAD} = 55^\circ$.

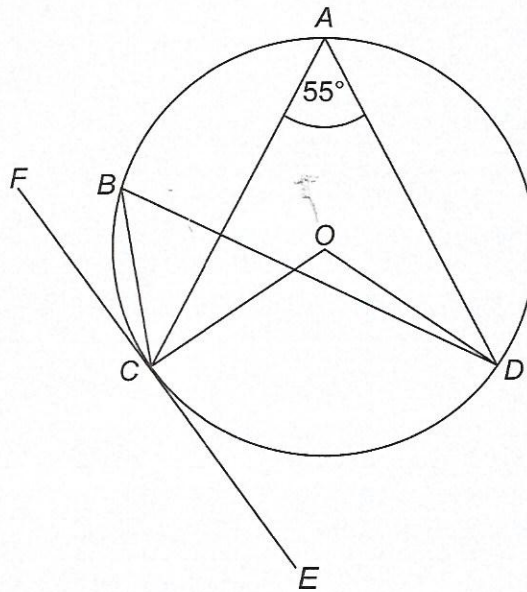

State, with a reason, the size of

- (a) \hat{CBD} , [2]
- (b) \hat{ECO} , [2]
- (c) \hat{COD} . [2]

Handwritten notes in red ink:
 $57 = 318$
 $37 = 22$

- 13 The diagram below shows a roof $ABCDEF$ of a house.
The size of $\hat{A}FD = \hat{B}EC = 56^\circ$. The roof is also such that $AF = DF = BE = CE = 6.25$ m and $AD = BC$. $AB = DC = 14.5$ m and $EF = 8.0$ m.

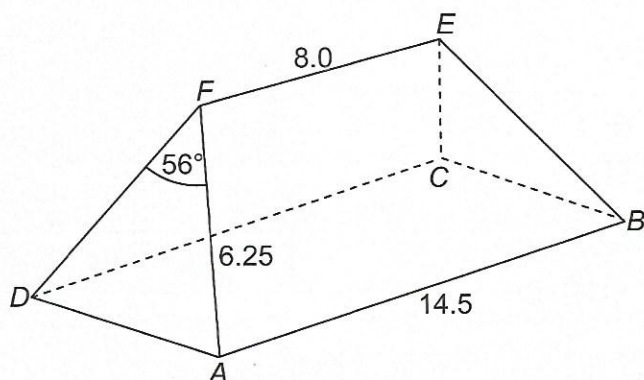

Calculate

- (a) the area of triangle ADF , [2]
 (b) the perpendicular distance from F to AB , [2]
 (c) the area of the face of the roof $ABEF$, [2]
 (d) the outer total surface area of the roof. [3]

- 14 Answer the whole of this question on a sheet of graph paper.

The table below shows some values of x and the corresponding values of y for the equation $y = x(x + 1)(5 - 2x)$.

x	-2	-1.5	-1	-0.5	0	0.5	1	1.5	2	2.5	3
y	18	6	0	-1.5	0	3	6	7.5	6	0	a

- (a) Calculate the value of a . [1]
 (b) Using a scale of 2 cm to represent 1 unit on the x -axis and 2 cm to represent 5 units on the y -axis, draw the graph of $y = x(x + 1)(5 - 2x)$ for $-2 \leq x \leq 3$. [4]
 (c) On the same axes, draw the graph of $3y + 5x = 15$. [1]
 (d) Use your graphs in (b) and (c) to estimate the values of x satisfying both $y = x(x + 1)(5 - 2x)$ and $3y + 5x = 15$. [3]
 (e) By drawing a tangent at $x = 2$, estimate the gradient of $y = x(x + 1)(5 - 2x)$ at $(2, 6)$. [3]

Answer the whole of this question on a sheet of graph paper.

A farmer has money to buy two types of breed of rabbits: the Chinchilla and the California White. The cost of one Chinchilla is P140 and the cost of one California White is P175 .

The number of Chinchillas is x and the number of California Whites is y .

- (a) Write down an expression, in terms of x and/or y , for the cost in Pula, of
- (i) the Chinchillas, [1]
 - (ii) the California Whites. [1]
- (b) The farmer has P3850 to buy the two types of breed of rabbits.
- Write down an inequality, in terms of x and y , to represent this information and show that it reduces to $4x + 5y \leq 110$. [2]
- (c) The number of California Whites the farmer can buy is more than 10 .
- Write down an inequality, in terms of x and/or y , to represent this information. [1]
- (d) At most $\frac{3}{5}$ of the rabbits bought should be California Whites.
- Write down an inequality, in terms of x and y , to represent this information and show that it reduces to $2y \leq 3x$. [2]
- (e) (i) Using a scale of 2 cm to represent 5 units on each axes, show, by shading the **unwanted** regions, the set of points satisfying the three inequalities in parts (b), (c) and (d). [3]
- (ii) Calculate the maximum number of rabbits the farmer can buy. [2]

(2015)