



BOTSWANA EXAMINATIONS COUNCIL  
in collaboration with  
UNIVERSITY OF CAMBRIDGE LOCAL EXAMINATIONS SYNDICATE  
Botswana General Certificate of Secondary Education

CANDIDATE  
NAME

CENTRE  
NUMBER

--	--	--	--	--

CANDIDATE  
NUMBER

--	--	--	--	--

**MATHEMATICS**

**0563/01**

Paper 1

**October/November 2011**

**1 hour 30 minutes**

Candidates answer on the Question Paper.

Additional Materials: Geometrical instruments

**READ THESE INSTRUCTIONS FIRST**

Write your centre number, candidate number and name in the spaces provided at the top of this page.

Answer **all** questions.

Write your answers in the spaces provided on the question paper.

If working is needed for any question, it must be shown below that question. Omission of essential working will result in loss of marks.

Do not use staples, paper clips, highlighters, glue or correction fluid.

The number of marks is given in brackets [ ] at the end of each question or part question.

The total of the marks for this paper is 50.

If the degree of accuracy is not specified in the question and if the answer is not exact, the answer should be given to three significant figures.

**THE USE OF ANY CALCULATING AID IS NOT  
ALLOWED IN THIS PAPER.**

**For Examiner's Use**

--

This document consists of **10** printed pages and **2** blank pages.

**Mathematical formulae for papers 1 and 2**

**Surface area and volume of solids**

Name of solid	Total surface area	Volume
cone	$\pi r^2 + \pi r l$	$\frac{1}{3} \pi r^2 h$
pyramid		$\frac{1}{3}$ base area $\times$ height
sphere	$4\pi r^2$	$\frac{4}{3} \pi r^3$

**Trigonometry**

Sine Rule  $\frac{\sin A}{a} = \frac{\sin B}{b} = \frac{\sin C}{c}$

$$\frac{a}{\sin A} = \frac{b}{\sin B} = \frac{c}{\sin C}$$

Area of a triangle  $= \frac{1}{2} ab \sin C$

For  
Examiner's  
Use

1 The table below shows the price of beef, in Pula per kg, at a butchery.

Beef	Price (Pula per kg)
Rump steak	26.50
Brisket	25.45
T-bone steak	28.30

(a) Mr Mokoti bought 5 kg of rump steak and 2 kg of brisket.

How much did he pay?

(b) Mrs Kefilwe paid P84.90 for a T-bone steak.

How many kilograms of T-bone steak did she buy?

(c) The butcher increased the price of beef per kilogram by 10%.

What will be the new price, in Pula per kg, of rump steak?

Answer (a) P ..... [2]

(b) .....kg [2]

(c) P ..... [2]

2 Describe fully the symmetry of the parallelogram below.

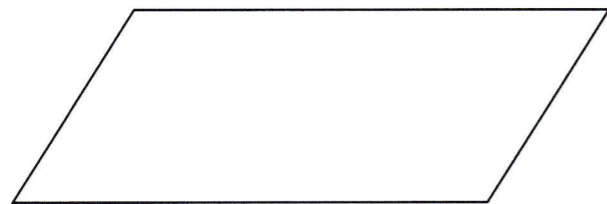

Answer ..... [2]

For  
Examiner's  
Use

For  
Examiner's  
Use

For  
Examiner's  
Use

3 The  $n$ th term of a sequence is given by  $6 - 2n$ .

(a) Write down the first 2 terms of the sequence.

(b) Find the position of the term  $-44$  in the sequence.

Answer (a) ..... [2]

(b) ..... [2]

4 The height of a tree is 3.2 m, correct to 1 decimal place.

Find the upper bound of the height.

Answer .....m [1]

5 Express  $d$  in terms of  $a$ ,  $t$  and  $w$  in the formula  $t = \frac{a-d}{w}$ .

Answer ..... [2]

For  
Examiner's  
Use

- 6 The mean selling price of two cows is P6750. The selling price of one of the cows is P7000.  
Calculate the selling price of the other cow.

Answer P ..... [2]

- 7 The diagram below shows a rectangular frame of outer length  $x$  cm and outer width 10 cm.  
The shaded part is a border of the frame. The border has a thickness of 2 cm.

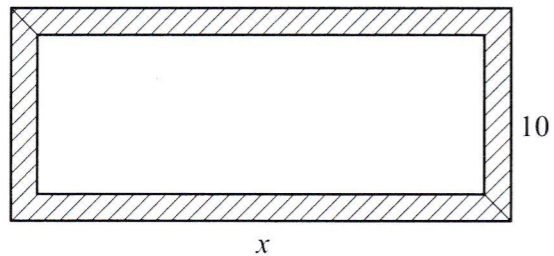

Express, in terms of  $x$ ,

- (a) the inner length,  
(b) the area of the border.

Answer (a) ..... cm [1]

(b) ..... cm<sup>2</sup> [3]

For  
Examiner's  
Use

- 8 The diagram below shows the net of a cube of side 5 cm. One face is labelled  $A$ . When the net is folded into a cube, the face opposite  $A$  is labelled  $B$ .

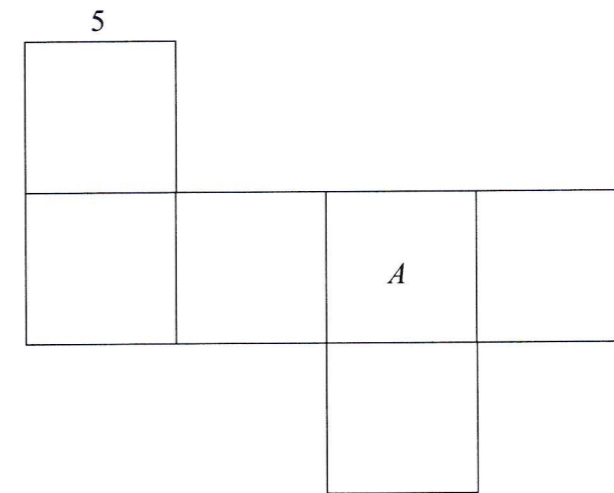

- (a) Label the face  $B$  on the diagram. [1]  
(b) Calculate the total surface area of the cube.

Answer (b) ..... cm<sup>2</sup> [2]

- 9 The point  $A$  is  $(-4, 5)$  and the point  $B$  is  $(2, -3)$ .

- (a) Write  $AB$  as a column vector.  
(b) Calculate the magnitude of  $\vec{AB}$ .

Answer (a)  $\begin{pmatrix} \phantom{0} \\ \phantom{0} \end{pmatrix}$  [2]

(b) ..... [2]

For  
Examiner's  
Use

For  
Examiner's  
Use

10 Solve the equation  $\frac{x}{2} - 3 = 1\frac{1}{2}$ .

Answer ..... [2]

11 The body surface area of a person,  $A$ , in  $m^2$ , is given by the formula

$$A = \sqrt{\frac{hm}{3600}}$$

where  $h$  is the height, in cm, and  $m$  is the mass, in kg.

Peo is 135 cm tall and has a mass of 60 kg.

Calculate Peo's body surface area.

Answer .....  $m^2$  [2]

12 A straight line passes through the points (2, -1) and (1, 3).

Find the equation of the line.

Answer ..... [2]

For  
Examiner's  
Use

For  
Examiner's  
Use

13 A trench is in the form of a cuboid of base length 24 m and width 10 m. The trench is filled with water to a depth of 50 cm.

Calculate the volume, in  $m^3$ , of the water in the trench.

Answer .....  $m^3$  [2]

14 The diagram below shows the shape of a floor of a house. The floor is in the shape of a semi-circle of radius 5 m, and a rectangle of length 8 m and width 6 m.

Take  $\pi$  as 3.14.

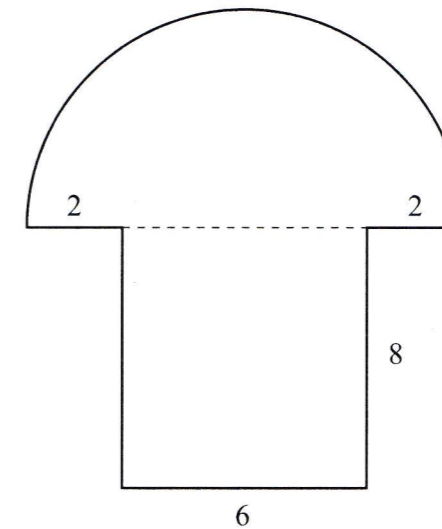

Calculate

(a) the length of the arc,

(b) the perimeter of the floor.

Answer (a) ..... m [2]

(b) ..... m [2]

For  
Examiner's  
Use

- 15** The diameter of a wheel of a car is 60 cm and that of its model is 1.2 cm.
- (a) The ratio of the length of the model to that of the car is expressed in the form 1 :  $n$ .  
Calculate the value of  $n$ .
- (b) The length of the car is 3.4 m.  
Calculate the length of the model of the car.

Answer (a)  $n = \dots\dots\dots$  [2]

(b)  $\dots\dots\dots$  cm [2]

- 16** A transmitter sends signals up to a radius of 40 km.  
The point  $T$  marked below shows the position of the transmitter.
- Use a scale of 1 cm to represent 10 km to show the maximum signal coverage from  $T$ .

•  $T$

[2]

For  
Examiner's  
Use

- 17** The distribution below shows allowances paid to 7 people.  
P1200, P1000, P1700, P2400, P1500, P2100 and P800.
- Calculate
- (a) the range,  
(b) the lower quartile,  
(c) the interquartile range of the distribution.

Answer (a) P  $\dots\dots\dots$  [1]

(b) P  $\dots\dots\dots$  [1]

(c) P  $\dots\dots\dots$  [2]

For  
Examiner's  
Use